

Sailor

Sailor

INSTRUKTIONSBOG FOR
SAILOR AT1500

INSTRUCTION BOOK FOR
SAILOR AT1500



A/S S. P. RADIO · AALBORG · DENMARK

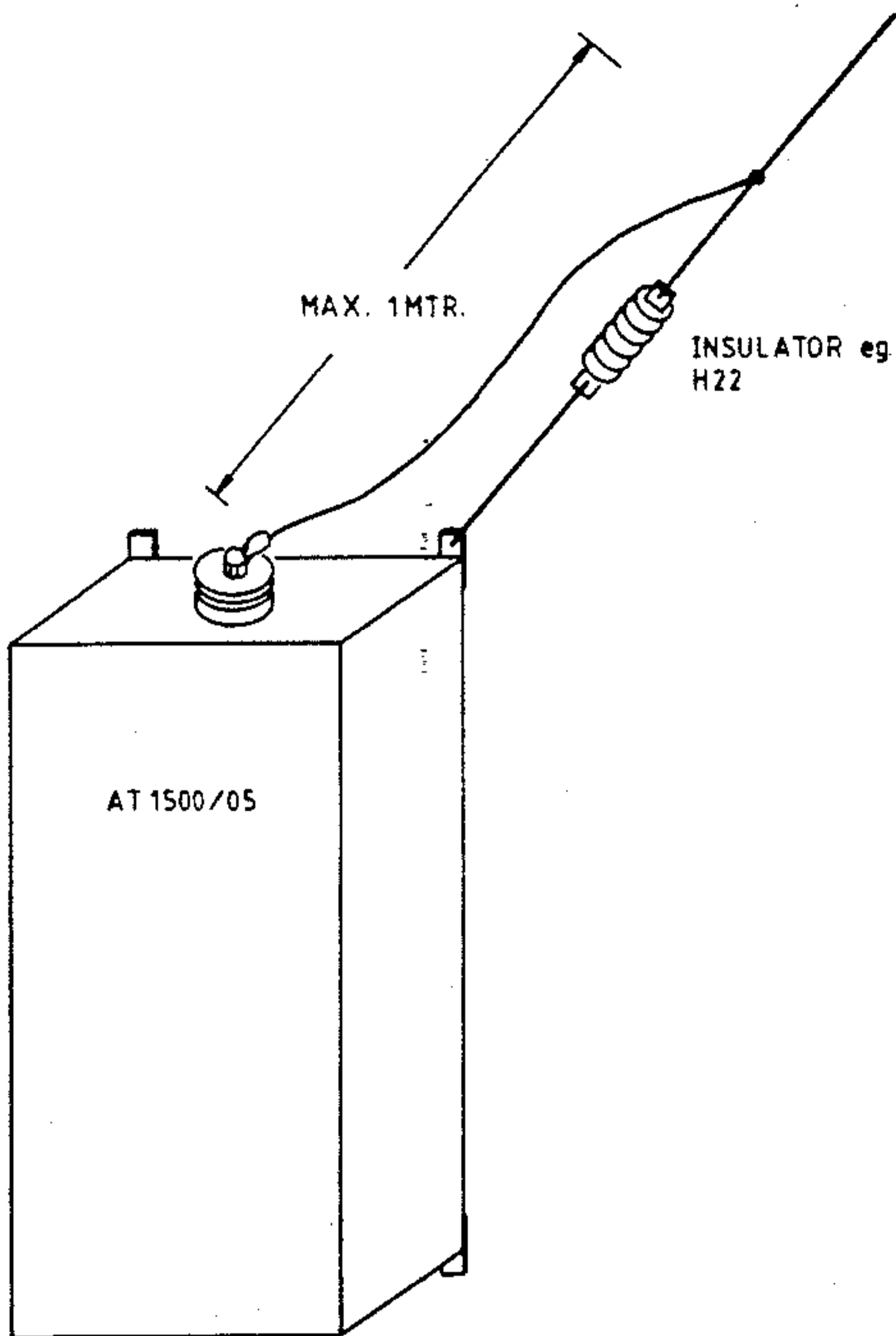

S. P. RADIO A/s AALBORG

Principle of strain relief

AT 1500/05

Tegn 23.02.88 SH

Kontr

Elzn

Forn

Forsrom

Elox

Attetles

Renses i spån

Rå

Konserv

Div

MATR

VARE NR

TEGN NR

4-0-25685

Målestok 1:5

CIRCUIT DESCRIPTION AT1500

The aerial coupler AT1500 is controlled from T1130.

When tuning, the relays RE101 to RE112 and RE201 are set for a code corresponding to the frequency, and the tune motor MO101 starts running until the SWR at the output of the PA-stage is acceptable.

The switch S101 gives information to T1130 about the position of the MO101.

The aerial current is measured with the current transformer TR201 and detected with D208 and C201, the output voltage is fed back to T1130.

When AT1500 is working as a dummy load the relays RE104 to RE111 are activated. Now L101 and L102 are connected in series with C101 (200 pF). L101 has an iron core with a high loss. The equivalent circuit of L101 is a coil in serial with a resistor of approx. 8 ohm. All the power fed into the dummy load is heating the iron core which has a good terminal contact to the chassis.

The codes for the relays in different aerial modes are listed in table 1.

TABLE 1

Two aerial duplex	RE101 to RE112 and RE201 are controlled from T1130
Two aeriels simplex	RE101 to RE112 and RE201 are controlled from T1130
One aerial simplex normal	RE101 to RE111 are controlled from T1130. RE201 and RE112 follows the microphone key.
One aerial simplex narrow	RE101 to RE111 are controlled from T1130. RE201 and RE112 are activated permanently.
Ground aerial	RE101 to RE112 and RE201 are off.
DF	RE101 to RE112 are off and R201 is activated.
Dummy load heat	RE104 to RE111 and RE201 are activated and RE112 is off.

GENERAL DESCRIPTION

SAILOR AT1500 is a 500 Watt aerial coupler.

SAILOR AT1500 is designed to be used together with SAILOR TRANSMITTER T1130.

SAILOR AT1500 is an automatic aerial coupler controlled from T1130.

SAILOR AT1500 is able to tune aerials from 5 metres to 14 metres in the frequency range from 1.6 MHz to 28 MHz.

SAILOR AT1500 is constructed for outdoor use.

SAILOR AT1500 has a built-in AERIAL RELAY.

SAILOR AT1500 has a built-in DUMMY LOAD.

SAILOR AT1500 has a possibility of tuning the transmitter aerial to the receiver.

SAILOR AT1500 has facilities to make open aerial and grounded aerial.

TUNE-UP PROCEDURE

When installing T1130/AT1500 or changing the aerial it is necessary to retune the pre-settings of AT1500. The procedure for this is described in the instruction book for T1130.

P101

POWER IN

TO ST104
ON CONNECTION
BOARD H1233

- CONTROL 2
- CONTROL 4
- CONTROL 5
- CONTROL 6
- CONTROL 7
- CONTROL 8
- CONTROL 9
- CONTROL 10
- CONTROL 11
- CONTROL 1
- CONTROL 3

- INVALID TUNING/180°
- MOTOR AERIAL CURRENT
- AERIAL CURRENT
- AERIAL RELAY
- AERIAL CURRENT

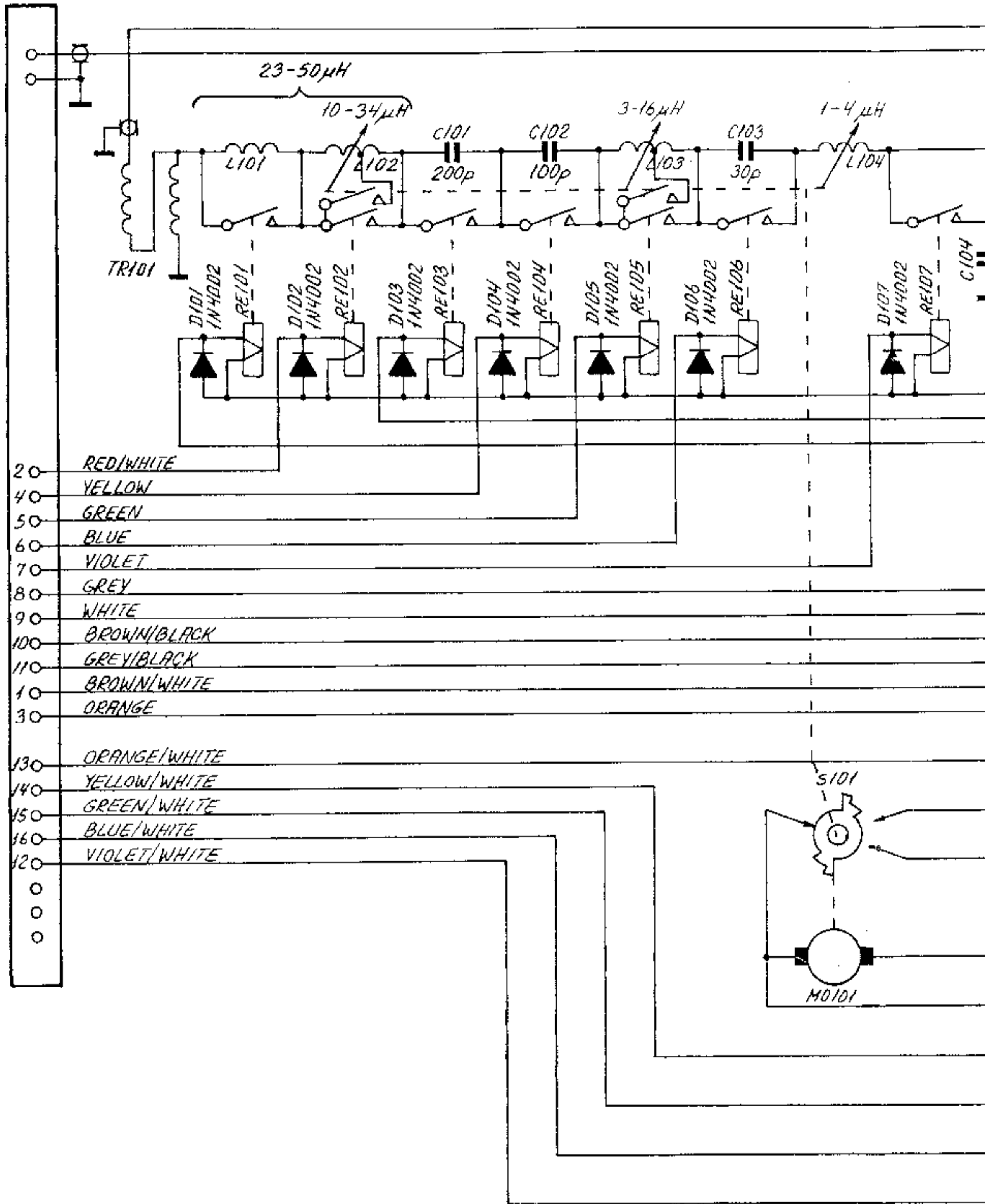

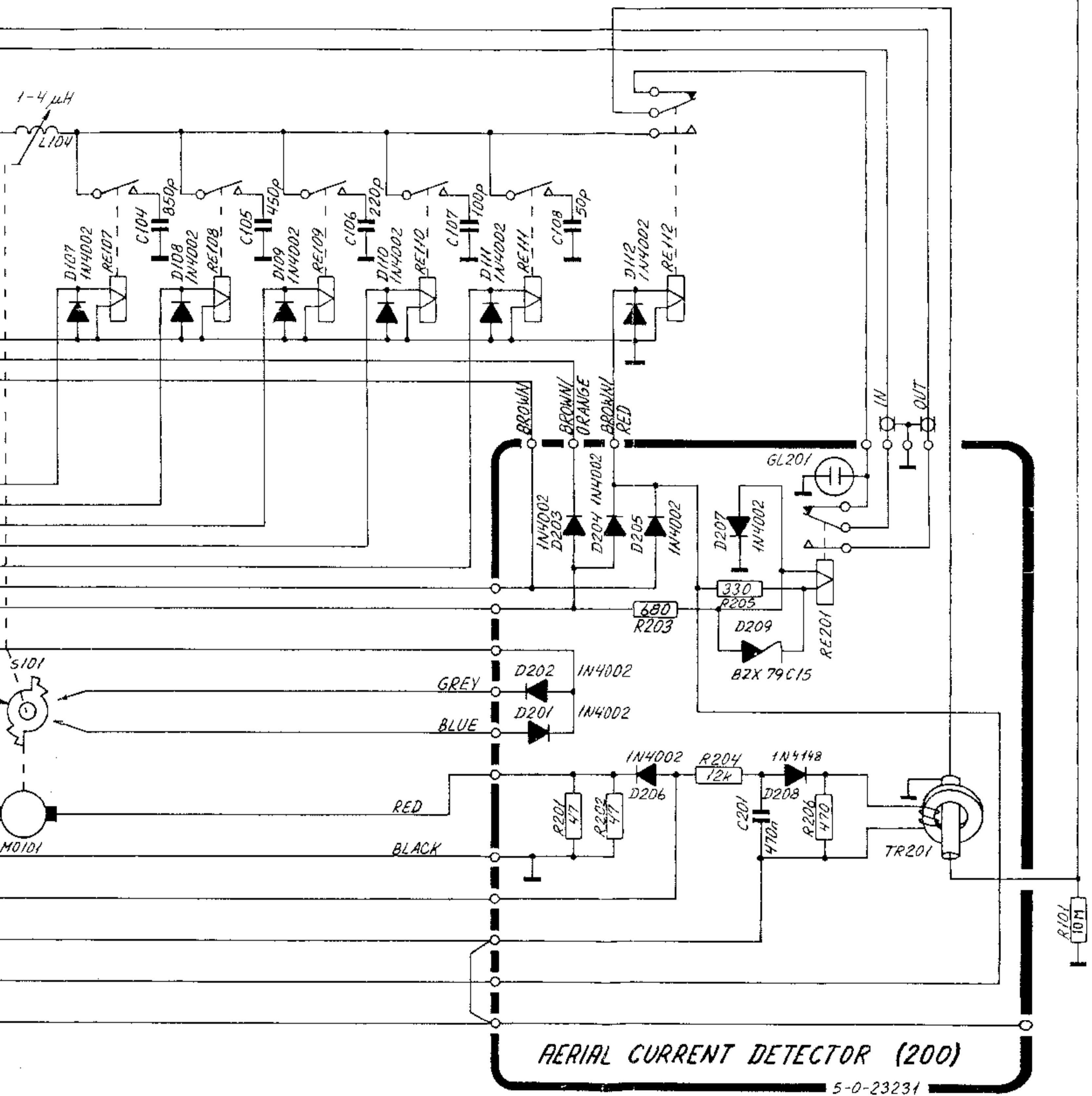

AERIAL CURRENT DETECTOR (200)

5-0-23231

**MAIN SCHEMATIC DIAGRAM
FOR AT 1500**

COMPL CATION
 AERIAL ENT DETECTOR (MODULE 200)

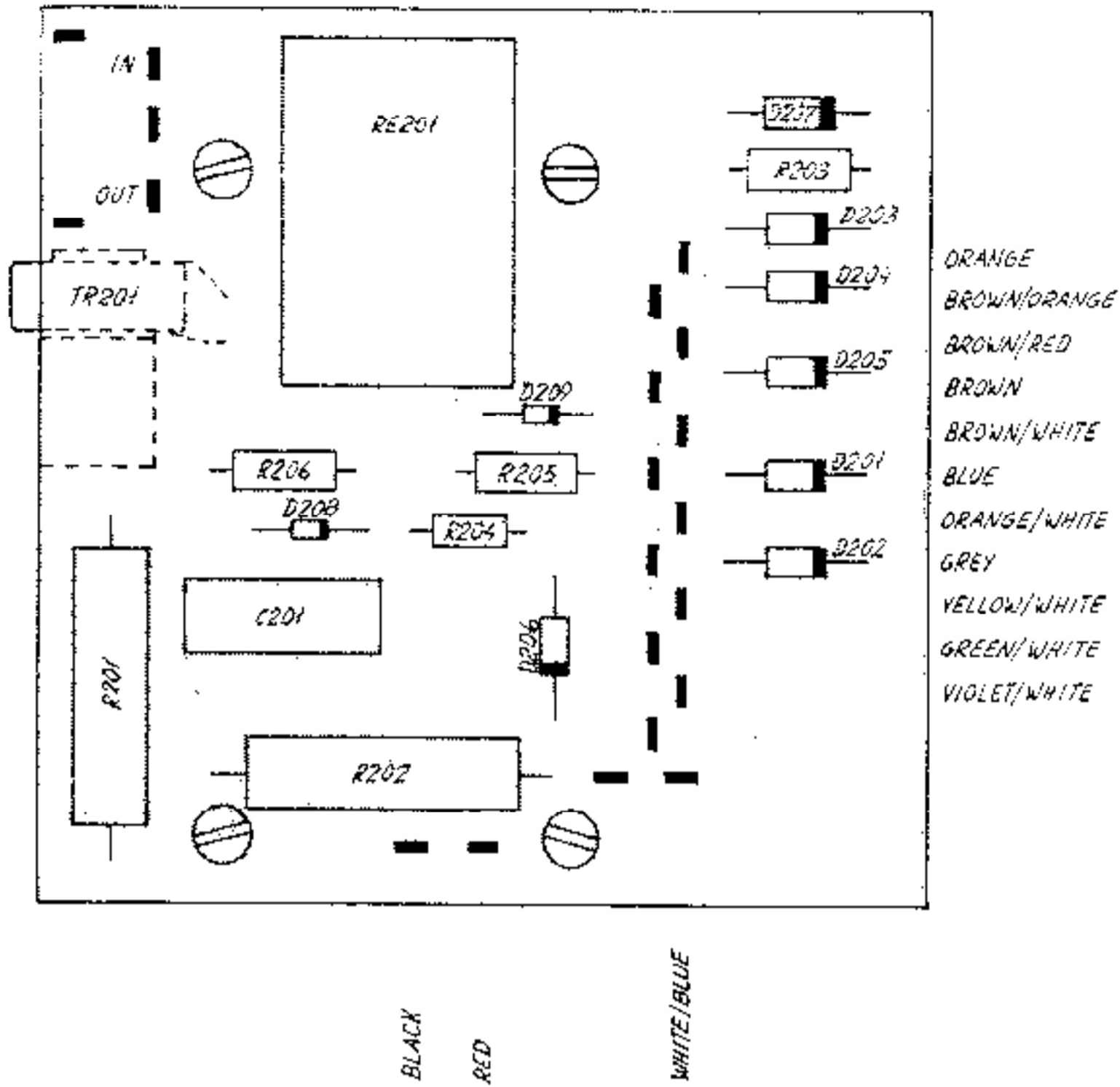

View from component side with upper side tracks.

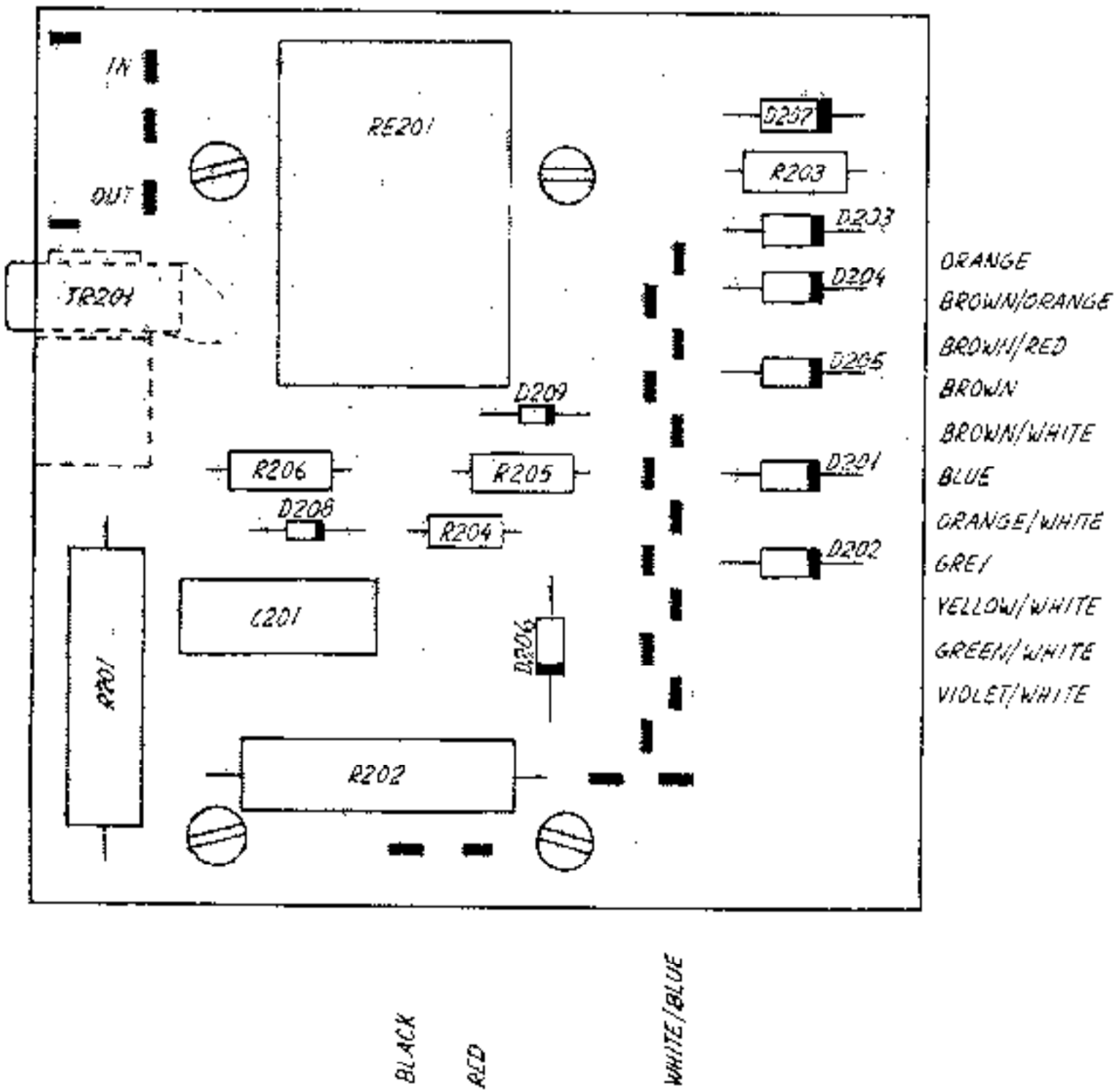

View from component side with lower side tracks.

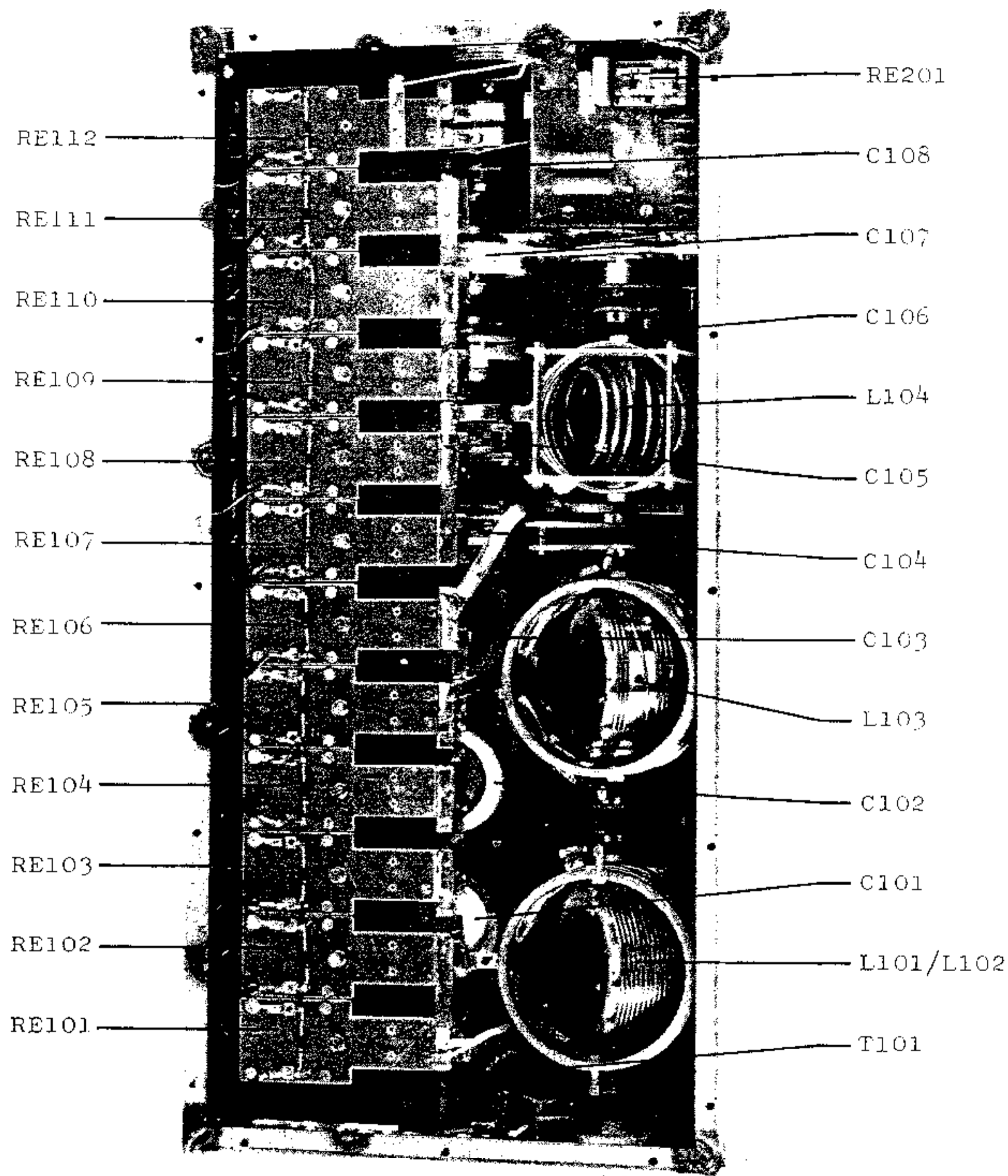

B		AERIAL CURRENT DETECTOR AT1500			1/1	
Symbol	Description			Manufact.		
C201	Capacitor polyester	470 nF	100V	Philips	2222 344 27474	
D201	Diode			Motorola	1N4001	
D202	Diode			Motorola	1N4001	
D203	Diode			Motorola	1N4001	
D204	Diode			Motorola	1N4001	
D205	Diode			Motorola	1N4001	
D206	Diode			Motorola	1N4001	
D207	Diode			Motorola	1N4001	
D208	Diode			ITT	1N4148	
D209	Diode, Zener			Philips	BZX79C15	
GL201	Neon Lamp			Siemens	B1 C90-Q69x151	
R201	Resistor	47 ohm \pm 5%	7W	Philips	2322 329 07479	
R202	Resistor	47 ohm \pm 5%	7W	Philips	2322 329 07479	
R203	Resistor	680 ohm \pm 5%	1.6W	Philips	2322 191 36801	
R204	Resistor	12 kohm \pm 5%	0.33W	Philips	2322 211 13123	
R205	Resistor	330 ohm \pm 5%	1.6W	Philips	2322 191 33301	
R206	Resistor	470 ohm \pm 5%	1.15W	Philips	2322 214 13471	
RE201	Relay	12V		National	NF2E-12V DPDT	
TR201	Transformer	TL274		S.P.		

D		CHASSIS AT1500		1/2	
Symbol	Description			Manufact.	
C101	Capacitor ceramic	200 pF	+20%	LCC	AAT 042
C102	Capacitor ceramic	100 pF	+20%	LCC	AAH 042
C103	Capacitor ceramic	30 pF	+20%	LCC	AAH 030
C104	Capacitor, Mica	850 pF		S.P.	
C105	Capacitor, Mica	450 pF		S.P.	
C106	Capacitor ceramic	220 pF	+20%	LCC	AAT 042
C107	Capacitor ceramic	100 pF	+20%	LCC	AAH 042
C108	Capacitor ceramic	50 pF	+20%	LCC	AAH 030
D101	Diode			Motorola	1N4002
D102	Diode			Motorola	1N4002
D103	Diode			Motorola	1N4002
D104	Diode			Motorola	1N4002
D105	Diode			Motorola	1N4002
D106	Diode			Motorola	1N4002
D107	Diode			Motorola	1N4002
D108	Diode			Motorola	1N4002
D109	Diode			Motorola	1N4002
D110	Diode			Motorola	1N4002
D111	Diode			Motorola	1N4002
D112	Diode			Motorola	1N4002
L101	Variometer			S.P.	
L102	Variometer			S.P.	
L103	Variometer			S.P.	
L104	Variometer			S.P.	
M0101	Motor			MAXON	41.023.038-00.00-097
P101	Jack			S.P.	
R101	Resistor	10 Mohm High Voltage	10% 1W	Philips	2322 244 13106
RE101	Relay			S.P.	ORF 1501
RE102	Relay			S.P.	ORF 1503
RE103	Relay			S.P.	ORF 1501
RE104	Relay			S.P.	ORF 1501
RE105	Relay			S.P.	ORF 1503
RE106	Relay			S.P.	ORF 1501
RE107	Relay			S.P.	ORF 1501
RE108	Relay			S.P.	ORF 1501
RE109	Relay			S.P.	ORF 1501
RE110	Relay			S.P.	ORF 1501

AT 1500

MODULE NO: 100

B CHASSIS AT 1500 2/2

<i>Symbol</i>	<i>Description</i>	<i>Manufaci.</i>	
RE111	Relay	S.P.	ORF 1501
RE112	Relay	S.P.	CRP 1502
S101	Switch	S.P.	